



VISION IN ACTION

Editor: Dr Denis Bulgin
Advertising Sales & Production: Chris Valdes

Spring 2018

Industry update from the UK Industrial Vision Association



UKIVA
**machine vision
conference**
& EXHIBITION

Bringing world-class companies from the vision industry together

Our exciting Keynote presentations will examine the use of vision in different types of autonomous vehicles. Take a look at the full Conference Programme and list of exhibitors on the centre pages.

Register to visit: www.machinevisionconference.co.uk

KEYNOTE 1

Venturer driverless cars project

At 10am, Professor Tony Pipe, Deputy Director at Bristol Robotics Laboratory, UWE will talk about the Venturer project. The Venturer Consortium, led by SNC-Lavalin's Atkins, consists of ten public, private and academic experts, including BAE Systems, Williams and Bristol Robotics Laboratory. This wide-reaching project assesses the responses of passengers and other road users to driverless cars as well as looking at the enabling technology and developing an understanding of the insurance and legal implications of increased vehicle autonomy. These are all crucial factors that will influence wide scale adoption of CAV capability. Two practical trials using the consortium's autonomous vehicle, BAE Systems Wildcat, have already been completed. The first was carried out in the Williams Advanced Engineering simulator and the second on roads under carefully controlled conditions. The Wildcat is equipped with a situational awareness system utilising complementary sensor technologies including radar and cameras.



KEYNOTE 2

Self-driving personal delivery robots

Henry Harris-Burland, VP Marketing from Starship Technologies, will start the afternoon session by discussing the development of advanced, self-driving personal delivery robots that can carry up to 22 lb of food or shopping in a locked compartment within a 2-mile (3km) radius, using pavements to make their deliveries. The robot is equipped with 9 or 10 cameras, radar, and ultrasonic sensors that create an "awareness bubble" allowing it to detect and avoid obstacles such as pedestrians, cars and cyclists. The company will bring a robot along to event so that visitors can see it in action.

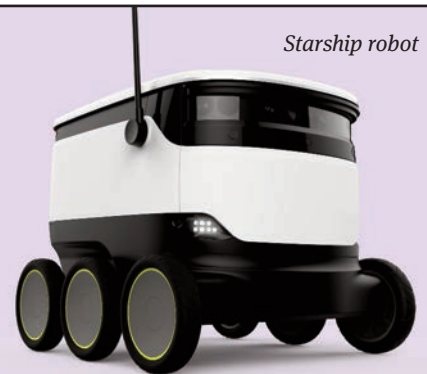

Starship robot





// NEW PROSILICA GT HIGH RESOLUTION CMOS CAMERAS

Eagle-eyed

Designed specifically to deliver high-resolution imaging in harsh operating environments with eagle-like precision, the Prosilica GT now offers the latest ON Semi PYTHON CMOS sensors with a resolution of 12, 16, and 26 Megapixels.

Find out more on www.alliedvision.com/eagle-eyed



FOREWORD by Paul Wilson



Following the resounding success of the first UKIVA Machine Vision Conference in 2017, we are confident that this year's event will be even better. As you will see from the centre page spread in this issue of Vision in Action, we have an exciting and educational program of seminars lined up, with two highly topical Keynote Presentations, all supported by an exhibition from more than 60 of the world's leading machine vision providers. I look forward to seeing as many people as possible at MK Arena, Milton Keynes on May 16th! Visitors can register at: www.machinevisionconference.co.uk/delegate-registration/.

I was extremely pleased to take part in the PPMA BEST STEM Day at the Mountbatten School in Romsey in Hampshire back in December and have the opportunity to show the students who attended how machine vision can be used in the real world. Even though the day was compulsory for the 124 Year 10 students who attended, I was impressed by both the level of enthusiasm that they showed and the solutions that they came up with for the tasks they were set. We got some very positive feedback and I am delighted that almost 25% of them have expressed some level of interest in attending a follow-up work experience placement. There is more detail on this STEM day elsewhere in this issue.

Encouraging the engineers of the future to embark on a career in machine vision continues to be an important issue for UKIVA members, and the STEM days are an invaluable way of sowing the seeds with the younger students. One way of providing a pathway into industry is via an apprenticeship, but to date there is no dedicated independent vision apprenticeship. Attendees at the recent UKIVA Annual Members' Meeting heard presentations from EEF, The Manufacturers Association, on the various stages involved in establishing such an apprenticeship. This would clearly be a major undertaking both in terms of time and resources and discussions on the best way forward are ongoing.

Paul Wilson, UKIVA Chairman

CONTENTS

Application Articles	4-12
UKIVA Machine Vision Conference Programme.....	15-18
Members News	21-29
Members Directory	30
Events, Training, Technical Tips	30

Free subscription contact
Christine Valdes
 T: +44 (0) 20 8773 5517
 E: chris.valdes@ppma.co.uk

We are always looking to improve
Vision in Action, for comments and
 feedback please email the editor
Denis Bulgin, In Press PR Ltd
 E: denis@inpress.co.uk

Design and Artwork: Barry Heath
 E: bmh@btinternet.com

Want to learn more about 3D?

Download our Guide to
 3D Imaging Techniques

www.clearviewimaging.co.uk/3d

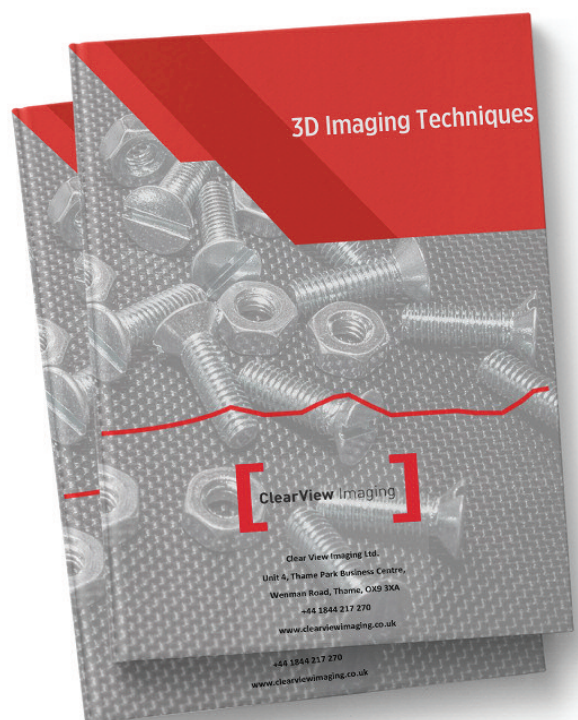
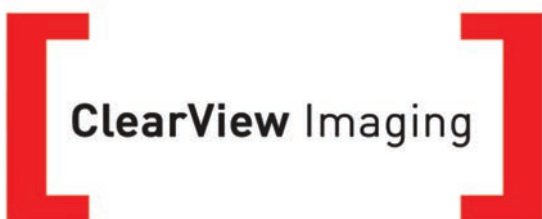

ASSOCIATION NEWS

PPMA BEST

PPMA BEST STEM DAY PROVES SUCCESSFUL

In December 2017, Jenton International and Scorpion Vision Ltd joined with PPMA BEST to hold a STEM (Science, Technology, Engineering & Maths) day at the Mountbatten School in Romsey, Hampshire. PPMA BEST (www.ppmabest.org.uk) is an independent charity, set up by the PPMA Group of Trade Associations to address the on-going skills shortage within the industries served by the Associations and to tackle short and longer term recruitment needs.



The event, run by the EDT, was attended by 124 Year 10 students. Staff from Jenton International and Scorpion Vision set the students, working in teams, two tasks to complete and were on hand to guide the students and act as the judges for each activity. This gave the students a fantastic opportunity to engage with engineers and learn about the process, packaging and machine vision industry and for potential career opportunities. The first task involved designing and building a roller loading mechanism, using supplied materials, to safely deliver a spherical package from a factory to a waiting vehicle using only gravity as a power source. In addition, the team had to consider its appearance as it would be visible to the local community. The second task was STEM Den. Each team had to select an item and improve it; build a model using K'Nex and deliver a 1 minute presentation to the STEM Den Dragons.

The event proved to be highly successful. PPMA BEST is in contact with the school to support the 30 students who may be interested in attending a follow-up work experience placement.

INDUSTRIAL VISION SYSTEMS WIN 2017 VISION AWARD

Industrial Vision Systems have won the 'Most Innovative Machine Vision Project' award for 2017-one of the PPMA Group Industry Awards. IVS combined artificial intelligence machine vision with cutting-edge robot automation to provide a state-of-the-art flexible automated vision inspection cell for a dual pump assembly line. The system was required for a fully automated production line inspection of six different parts with a total of 63 variants, with the flexibility to add more parts and variants in the future.

www.ukiva.org

APPLICATION ARTICLES

Editorial material in this section is provided by UKIVA Members. Content accuracy is the responsibility of individual UKIVA Members.

ACROVISION

www.acrovision.co.uk

Laser wire stripping inspection solution

Laser stripping of electrical wires is used where conventional means are not possible. It is high precision and achieves unrivalled quality. Acrovision was tasked to provide a vision system to inspect individual wires of 100µm in diameter (70µm after stripping) within a vascular/heart catheter handle assembly machine. The essential requirement was to automate checking that the wires are all loaded, and check the odd wire (coloured) has not been loaded. There were also two desirable criteria; check wire spacing, to make sure they are in the laser strip zones, and check that the wires have been stripped.

Camera and lighting positions were restricted as they needed to be mounted in a very compact, pre-designed enclosure. They also had to be positioned to make sure that they were clear of the laser beams that were stripping the wires. The camera needed to be positioned far enough away from the product to be out of the way of the operator's hands.

The precision measurements required a Field of View of 50mm, which is a challenging requirement for a 'smart camera' configuration, which was required to meet the customer's budget.

Using a single light, two exposure set-up, it was possible to pick out each individual wire as well as the stripping mark. To differentiate the dark wires from the bright wires, a low angle diffuse light at 90° to the camera angle was used. With this view the dark and bright wires have a very different appearance. The background needed to have a uniform greyscale value in-between the dark and bright levels. Acrovision provided a reliable vision solution using a Cognex In-Sight vision system and a complex combination of vision tools such as edge, measurement, and histogram. The camera system is connected to the customer's host program to enable communication to set up the relevant operating conditions for each job variant.



Wire inspection system

ALLIED VISION

www.alliedvision.com

Space robots need machine vision cameras to see

Space robots are already becoming reality and rely on high-performance industrial cameras to see like humans. Robots are designed for space exploration and particularly for dangerous tasks such as repair work outside of spacecraft to avoid risking the lives of astronauts. Remote planets such as Mars require months of travel to reach, which is why only machines have explored it so far.

Unlike industrial robots, space robots are designed to be as close to humans as possible in terms of size and morphology. This is because room is very limited in spaceships or the International Space Station (ISS), and there is no possibility to setup a



*Rollin' Justin space robot
(Courtesy DLR (CC-BY 3.0))*

APPLICATION ARTICLES

dedicated, tailored workspace for a robot. Robots must be able to use the same tools and control panels as the human crew or even collaborate with humans. They also need to be able to accomplish more diverse tasks than automated systems on the factory floor. Two such examples are Robonaut 2 (R2), designed by NASA in co-operation with General Motors, and Rollin' Justin, a robot currently under development for future Mars exploration at the German Aerospace Center (DLR). R2 is actually already operating aboard the ISS.

3D vision is important to enable space robots to precisely locate and grab objects and perform tasks such as plugging devices or operating switches. This can be achieved with a combination of several area scan cameras, time-of-flight cameras, and other sensors. Both R2 and Rollin' Justin rely on Allied Vision cameras for stereoscopic vision in the visible spectrum. R2 has two Allied Vision Prosilica GC cameras built into its head, and Rollin' Justin has two Allied Vision Manta cameras mounted on both sides of its head. This allows the robots to have a better sense of depth when capturing images of their environment. Rollin' Justin has been demonstrated catching balls tossed in its direction and preparing coffee with a capsule coffee machine.

FRAMOS

www.amos.co.uk

How perceptual computing enables an entire new class of imaging applications

3D sensing technology is key to making human-machine-interaction natural and intuitive. This "perceptual computing" adds human-like sensing and intelligence to machines, allowing them to interact with their environment and users and to learn from one interaction to the next. 3D sensing is now ready for the mass market, creating future technologies with turnkey technology, affordable economics, and market demand.

Perceptual computing has the capacity to enable new intelligent applications for drones, industrial robots, home robots, and other consumer devices. Coffee machines will be able to recognise and identify users and their preferences;



Intel® RealSense™ D4

individuals will be able to control devices with gestures. Cleaning robots will be enabled to map their surroundings; intelligently avoid obstacles or be able to detect valuables and act accordingly. In industry, 3D sensing technology will enable pick-and-place robots to mimic their human co-workers while avoiding any collisions while in motion. Drones will be able to track people and recognize obstacles. Merging many forms of technology and data streams surveillance and security applications can intuitively use depth information to navigate and monitor changes to the environment for the interpretation of many situations.

New 3D sensing products, like the Intel® RealSense™ technology line, improve perceptual imaging and enable a whole new level of embedded vision capability. It is a suite of components that, when integrated into a device or machine, enable it to comprehend and interact with its environment in a truly 3-dimensional way. The product line includes a stand-alone vision processor with enhanced depth functionalities, multiple turnkey depth modules, cameras, optimized SDK, software, and tools. High-quality depth sensing is based on a dedicated vision processing ASIC. OEMs and vision engineers can easily implement human-like 3D sensing in their applications. Imaging and vision experts can assist customers using 3D sensing technology to bring cutting-edge applications to realisation and to allow machines to see and think.

ences; individuals will be able to control devices with gestures. Cleaning robots will be enabled to map their surroundings; intelligently avoid obstacles or be able to detect valuables and act accordingly. In industry, 3D sensing technology will enable pick-and-place robots to mimic their human co-workers while avoiding any collisions while in motion. Drones will be able to track people and recognize obstacles. Merging many forms of technology and data streams surveillance and security applications can intuitively use depth information to navigate and monitor changes to the environment for the interpretation of many situations.

ASSOCIATION NEWS

EXHIBITION BONANZA IN 2018

The exhibition season gets underway with a bang for the UKIVA on May 16, 2018 with the second UKIVA Machine Vision Conference and Exhibition at MK Arena, Milton Keynes UK. More information on this exciting event can be found on the front page and the centre page spread of this issue and at www.machinevisionconference.co.uk.

The PPMA Show will be taking place at the NEC on 25 -27 September 2018 and 15 UKIVA members have already signed up to exhibit, reinforcing the importance of industrial vision in this processing and packaging sector. 2018 also sees the return of the biennial VISION Show in Stuttgart, Germany. The dates for this are 6 - 8 November 2018. The VISION Show attracts around 600 visitors from the UK and a number of UKIVA members will be exhibiting there, and once again the Association will have a stand at the show.

NEW MEMBERS

UKIVA is delighted to welcome 3 new members:

B&R Industrial Automation is an innovative automation company which combines state-of-the-art technology with advanced engineering to provide customers in virtually every industry with complete solutions for machine and factory automation, motion control, HMI and integrated safety technology.



Heuft Systemtechnik GmbH provide modular systems to enhance quality, safety and efficiency when filling and packaging beverages, food and pharmaceuticals. Unique camera, X-ray and image processing technologies for a precise empty and full container inspection, trend-setting labelling technology and smart tools for container flow optimisation, production data acquisition and performance analysis safeguard product quality and line efficiency sustainably.



Tamron is a manufacturer of a wide range of original optical products, from interchangeable lenses for SLR cameras to various optical devices for both the general consumer and OEM. Tamron makes optical products that contribute to a range of different industries. These include: interchangeable lenses for SLR cameras, digital camera lenses, video camera lenses, lenses for automotive applications, IP and CCTV lenses, lenses for long wavelength infrared cameras, ultra-precision optical components and more.



VISION. RIGHT. NOW.

Innovative products, intelligent consulting and extensive service. Solve your machine vision projects with speed and ease by working with STEMMER IMAGING, your secure partner for success.

Share our passion for vision.

► www.stemmer-imaging.co.uk

IDS IMAGING

www.ids-imaging.com

Embedded vision system maps disaster zones

The AKAMAV working group from the Braunschweig University of Technology, Germany, which is supported by the Institute of Flight Guidance (IFF) at TU Braunschweig, has utilised an embedded vision system in a specially-equipped multicopter to deliver real time maps from disaster zones. These can help rescue teams with their mission planning.

Here, a large overall image is produced by rapidly stitching together individual images. AKAMAV used the ODROID-XU4 single board computer, with an 8-core ARM CPU and a UI-3251LE-C-HQ board-level USB3.0 camera from IDS with a 2 megapixel CMOS sensor and an S-mount lens holder. The image processing software was developed using the OpenCV open source computer vision library and C++. The camera is integrated using the uEye camera's versatile API, which is identical for all IDS cameras irrespective of the interface technology (USB 2.0, USB 3.0, or GigE) being used. This allows developers to work on projects on a desktop PC then transfer them directly to the embedded computer.

The multicopter operates autonomously using GPS with its area of operation defined using an existing georeferenced satellite image. The board-level computer is connected to the aircraft system's autopilot via a USB interface and also receives information on the current latitude and longitude, barometric altitude, and height above the reference ellipsoid. The software extracts landmarks, or features from acquired images and matches them to allow the images to be formed into a complete map. At a flight altitude of around 40m and a scaled image resolution of 1200 x 800 pixels, the ground resolution is approximately 7 cm/pixel. If there is a radio connection between the multicopter and the control station, the stitching process can be tracked live from the ground and the complete map can be accessed remotely once the mapping process is finished. If not, the map can be copied to an external drive once the multicopter has landed.

*Multicopter*

IFM ELECTRONIC

www.ifc.com/uk

3D sensor on a tractor - on the way to agriculture 4.0

Agriculture 4.0 is the application of Industry 4.0 technologies in an agricultural context. The pressures on price, quality and environmental concerns mean that agricultural machines have to assume more and more automated tasks - preferably without the intervention of an operator. Sensors play an important role. Their measurements are further processed by a controller and converted into commands for the actuators. All components and systems must communicate with each other without any interruptions and accommodate the harsh environments in agricultural machinery.

When harvesting grass or cereals, the cut grass or the straw that remains is raked into windrow lines in the field for collection by a tractor-drawn baler. This must be towed as exactly and continuously as possible over the windrow. Line guidance can be automated using a 3D sensor system from ifm electronic, which is particularly resistant to shock and vibration and virtually wear-free. The photonic mixer device (PMD) time of flight technology creates a three-dimensional image of the environment. Distances can be determined with a resolution of 64 x 16 pixels. Very good windrow recognition can be implemented where the baler is always pulled exactly over the windrow and the speed of the tractor can be optimised. Balers have an optimum working range for the quantity flow. If it is too small at low speeds, productivity in the harvest time window suffers. If the speed is too high, the baler is overloaded and there are delays due to machine downtime. By determining the size of the windrow to measure the quantity flow, the 3D sensor system allows optimisation of the speed.

To implement applications as easily as possible, the sensor system processes the large 3D volume data using two powerful integrated 32-bit processors. Easy tasks such as distance measurement or area surveillance are already implemented in the sensor. Typical functions such as minimum, maximum and average distance are available. This pre-processed data or the complete 3D data is communicated to a higher-level controller via CANopen or SAE J1939. An additional interface for Fast Ethernet UDP is available which transfers the complete distance information for all pixels up to 50 times per second. The controller can evaluate this data as required.

*3D sensors mounted on tractor*

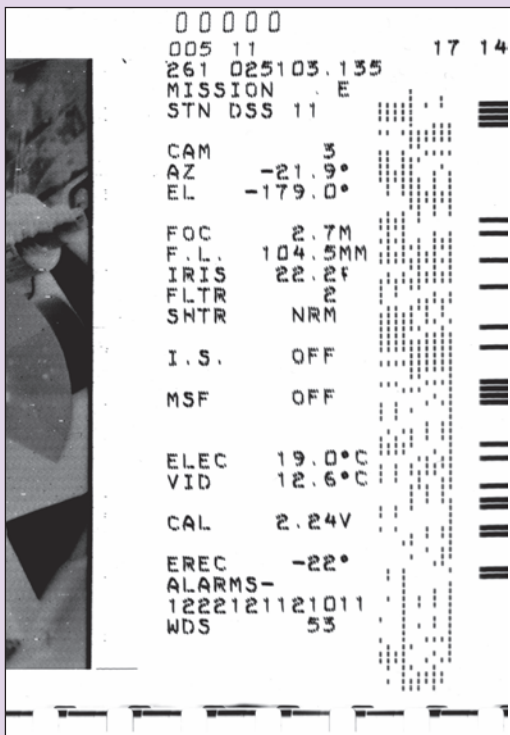

Difficult dot matrix characters on Surveyor images

MATROX IMAGING

www.matrox.com/imaging

Preserving historic images of the Moon's surface

The University of Arizona's Lunar and Planetary Laboratory is home to the Space Imagery Center, a NASA Regional Planetary Image Facility. In 2015, NASA funded digitisation of the film images and data from the Surveyor moon landers that have been in storage since the 1960s. The goal is to create a searchable archive for inclusion in the NASA Planetary Data System, a collection of data products from NASA planetary missions.

Between 1966 and 1968, the five successful Surveyor missions returned over 92,000 individual images of the moon's surface. The only surviving copies of these images were on special film recorded from a precision CRT display monitor using a 70mm film camera. Many of these frames contained dot matrix text characters similar to old printers using a 7x9 teletype-style character, making it difficult to find suitable optical character recognition (OCR) software.

An image scanning system from Stokes Imaging captured between four and eight frames per minute as high-resolution TIFF images, resulting in over 92,000 individual images. Adobe® Photoshop® and MATLAB software were then used to identify the details and create large composite mosaic images. Manual error checking was also required since the decoding of the dot-field data relied on calibration lookup tables created from the original 1966 pre-launch test data. Inconsistencies with the original film recording transport mechanism meant that with each different roll of film, the spacing of the frames and lateral positioning of the image shifted. This resulted in images with text in different places, as well as some images tainted with artifacts. Moreover, the data fields have human readable text with varying number of characters.

Matrox's solution utilised one of its efficient and accurate OCR software tools to read the dot matrix characters, taking just a few minutes per roll. An almost perfect read from nearly 4,500 different image files was achieved, compared with accuracy rates of 75% to 85% with the original approach. To date, the Matrox software has helped tackle data from Surveyor 5, and will prove a valuable tool for data from Surveyor 6 and 7, along with mission materials from other NASA projects and explorations. More information is available at www.matrox.com/imaging/en/press/feature/other/nasa/.

MULTIPIX IMAGING

www.multipix.co.uk

Drone detection system – Sky Patriot

Multipix introduce Rinicom and their flagship drone detection system called Sky Patriot. Using sophisticated artificial intelligence and state of the art video analytics algorithms, Sky Patriot is capable of detecting, classifying and tracking drones up to several kilometers away. A powerful user interface gives the operator full situational awareness and the information needed to make decisions. Detected drones may be automatically neutralised with an optional integrated jammer.

Sky Patriot may be used as a stand-alone system or as part of a multiple sensor solution,

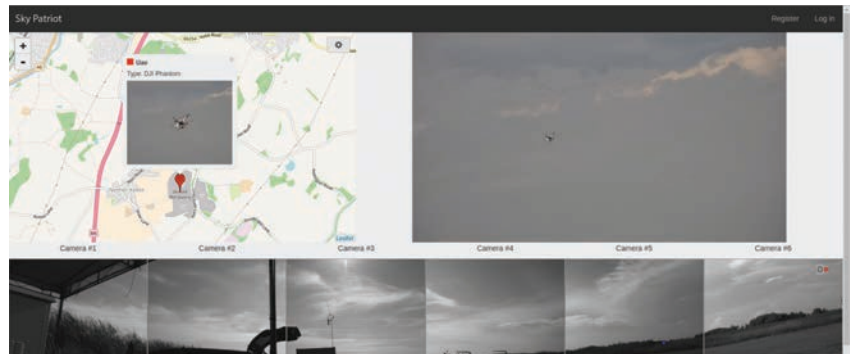

Skypatriot

including RF detection and radar. The Sky Patriot AI data fusion engine ensures nothing is missed, giving accurate real-time drone positional and classification information.

THE FLEXIBILITY TO ADAPT. THE POWER TO TRANSFORM.

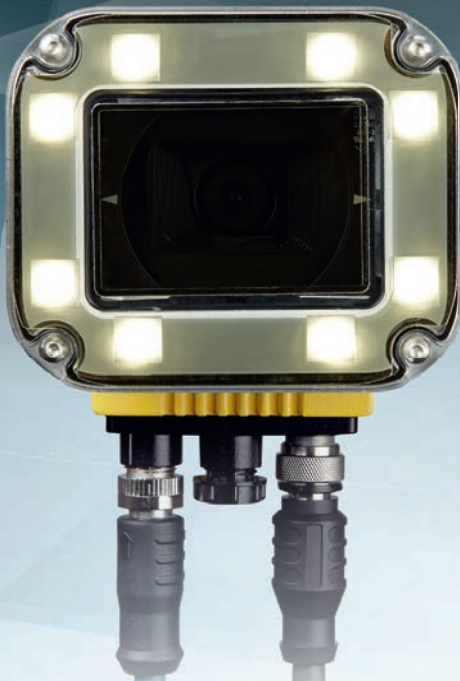

With hundreds of custom configurations, the highly modular, highly powerful, next generation In-Sight[®] 7000 vision system removes any limits to building your vision.

Flexibility—Field-configurable lenses, lights, filters, and covers for custom applications.

Performance—Powerful vision tool library with new, blazing-fast PatMax RedLine.™

Ease of Integration—Fast and intuitive application development with EasyBuilder.®



COGNEX

www.cognex.com/InSight7000



Inspired by Nature **weCat3D** Sensors



Dominance in 70 Models.

- Measuring ranges from 30 to 1300 mm in the X direction
- Maximum resolution: 2.0 μm in the Z direction
- Up to 12 million measuring points per second



www.wenglor.com/weCat3D

With more than 25 years of experience and over 15,000 installed solutions, wenglorMEL is a pioneer in the field of two and three-dimensional object measurement. The 2D/3D Sensors project a laser line onto the object to be measured and then record it by means of an integrated camera. Two and three-dimensional surface and volume profiles can thus be calculated with the help of point clouds.

Contour Inspection

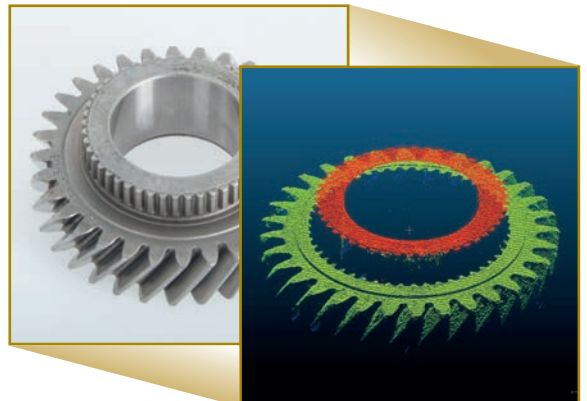
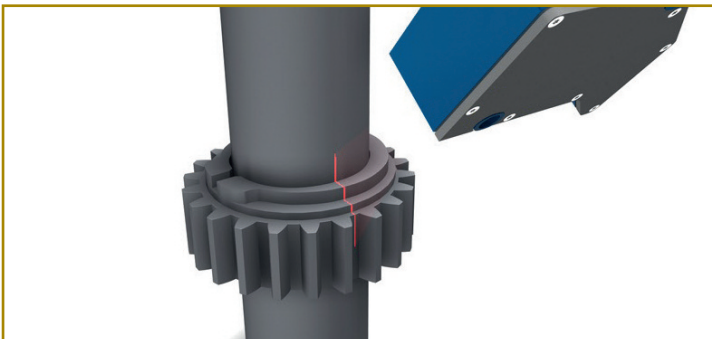

Profile Measurement

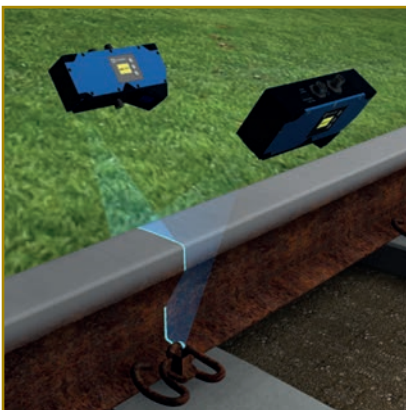

Sealant Bead Inspection

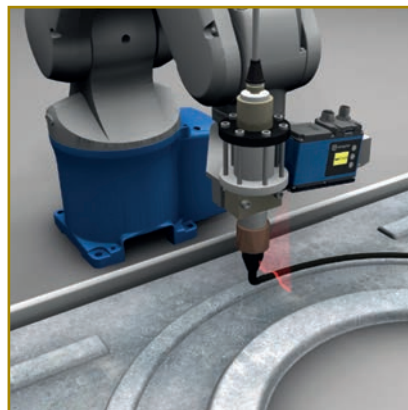

Volumetric Measurement

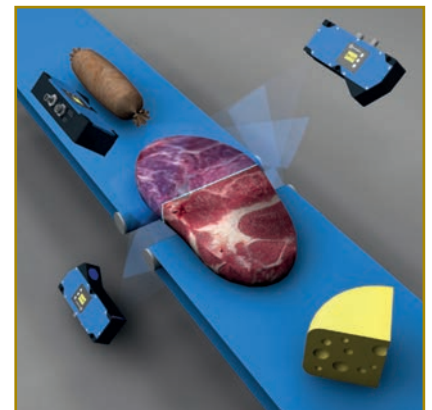

wenglor sensoric ltd.

Unit 2, Beechwood | Cherry Hall Road, Kettering Business Park | Kettering, Northants NN14 1UE | UNITED KINGDOM
Tel. +44 (0)1536 313580 | info.uk@wenglor.com

The high flexibility of the system allows it to be used in multiple public security applications such as the surveillance of stadiums or other big public events. One of the most important hardware components in the system is the camera, which is needed to reliably deliver high quality images, even in difficult outdoor lighting conditions. The cameras must work in daylight as well as under low light conditions while being able to secure a wide field of view.

The Sky Patriot uses the new Basler acA4024-29um camera which features Sony's new STARVIS sensor. Due to the use of Exmor R back illumination technology, these rolling shutter sensors offer exceptional image quality coupled with high speed and low noise. Combined with Basler's know how in sensor integration and great feature set, they offer Rinicom the ability to offer a high performing system to their customers. With these cameras, Sky Patriot can see further, faster and more accurately than any human.

In order to be able to take full advantage of the performance of the sensor with its small pixels, the corresponding lens has a big impact. In this case, the decision was made to use the Basler lens, which has a great pixel resolution of 2.2 μm and delivers a sharp image.

SICK (UK) LTD

www.sick.co.uk

LabelChecker helps confectionery giant out of sticky situation

SICK worked closely with a European confectionery manufacturer to develop an 'off-the-shelf' label reading and verification solution – the first to be developed in SICK's pioneering AppSpace programming environment. Developed initially for the customer's high-speed chocolate packing line, engineers perfected the all-in-one LabelChecker with the ability to read and verify text, numbers bar codes and 2D codes, as well as inspecting label design and print quality. The solution is based on the SICK InspectorP vision camera which provides an integral quality control system without the need for an additional evaluation unit.

The customer needed to find an alternative to using several different cameras and quality assessment software for reading and inspecting labels on several different production lines at speeds up to four labels a second. A typical finished pack required a product identification label which carried 1D and 2D barcodes, alphanumeric and brand design, all of which had to be verified for validation and positioning as part of quality control.

Thanks to the AppSpace vision development tool, the LabelChecker is now available as a ready-to-use package with easy configuration and visualisation via the web server interface and no need for specialist programming or additional software licenses. The LabelChecker's capabilities encompass OCR and OCV in multiple regions and lines, including overlapping characters, as well as dot matrix printed and indented (peened) text. In addition, many standard types of 1D and 2D code can be read and verified including multiple codes in one image and comparison with alphanumeric print. Label design quality control includes type checking, print quality, shape, rotation, tilt and location checking and comparison with pre-learned label images with compilation of quality statistics.

STEMMER IMAGING

www.stemmer-imaging.co.uk

Machine Vision ensures excellence in paper processing

Swiss company Hunkeler has been serving the printing industry since 1922. The 'Hunkeler Control Platform' supplies scalable solutions for quality and production inspection. Stemmer Imaging has been Hunkeler's machine vision partner since 2010, supplying line scan cameras, contact image sensor technology and all the necessary vision hardware for Hunkeler's web inspection systems. Mitsubishi Electric Line Scan Bars were adopted for use in future web inspection systems in 2013. More than two hundred WI6 web inspection systems, designed for integration into Canon colour stream printers, are installed all over the world in many fields of application such as transactional, trans-promo, direct mailing, publishing, lotteries, pharma, security printing and many more.



LabelChecker inspecting chocolates



Web inspection using Mitsubishi Electric Line Scan Bar (Courtesy Hunkeler)

APPLICATION ARTICLES

Mitten im Markt Messe Stuttgart



THE OF VISION TECHNOLOGY

06 - 08 November 2018
Messe Stuttgart
Germany
www.vision-fair.de



VISION
World's leading
trade fair for
machine vision

The new high speed CX versions of the Mitsubishi Electric Line Scan Bars will be used in the new WI8 web inspection system integrated into the latest DP8 Dynamic Perforator machines. These real time digital printing quality inspection systems detect printer oriented and user oriented defects, and are integrated with Hunkeler's tracking platform for end to end production monitoring and tracking.

The CX models are especially designed for very high inspection speeds, allowing for extremely fast data output via one or two CoaXPress interfaces depending on the size of the sensor. This setup allows the scanning of paper at a speed of 138 m/min with a maximum resolution of 600 dpi. The commonly used resolution of 300 dpi enables reliable inspection of up to 450 m/min, and inspections with 150 dpi resolution even allow speeds of 1,200 m/min.

The web inspection system provides extensive real-time functionality on 100% of the printed pages. Some examples are standard inspections of up to five A4 pages in parallel duplex independent pages. Presence, size and position measurements for graphical objects on the page, the detection of smearing and streaks, print registration verification down to 40 microns with standard 300 dpi resolution, colour grading, 1D, 2D ANSI and postal code grading, decoding and data validation can be performed. Optional dynamic real-time marking and I/O driving based on the inspection status are also possible, which is usually used for inline lottery or label inspection applications.



Your Partner for Machine Vision

Driven by excellence, our inspection systems safeguard the quality and integrity of our clients' brands worldwide.

Whether you require assistance with simply sourcing the best solution for your requirements or the design and implementation of a turnkey vision solution, Olmec have the expertise to help.

Let's work together!

www.olmec-uk.com

01652 631960

Olmec
quality through innovation

Machine Vision Components

The Imaging Source offer a comprehensive range of USB3.1, USB3.0, USB2.0 and GigE cameras for Machine Vision applications



NIT Short Wavelength Infra red cameras are ideal for applications in the range of 900 to 1700nm



Teledyne e2v Line Scan cameras offer high speed and high resolution solutions for Machine Vision developers



Alrad offer a wide range of lighting solutions for Machine Vision and Microscopy applications from leading manufacturers

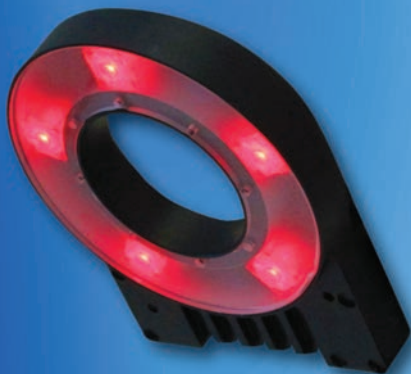

**ALRAD
IMAGING**

Telephone: 01635 30345

Email: sales@alrad.co.uk

Web: www.alrad.co.uk

Mobile: www.alrad.mobi



**YOU
DECIDE
WHAT'S
NEXT!**

**APP YOUR
SENSOR®!
IDS: NXT**

powered by
HALCON



IDS NXT – The Vision App-Based platform from IDS.

CREATE YOUR OWN IDS: NXT-VISION SOLUTION

App your Sensor®! IDS NXT is a new generation of vision app-based sensors and cameras. Whether you need to read codes, recognise characters, faces, or number plates, find, measure, count or identify objects. Develop your own customised vision app and install it on your IDS NXT device just like on a smartphone.

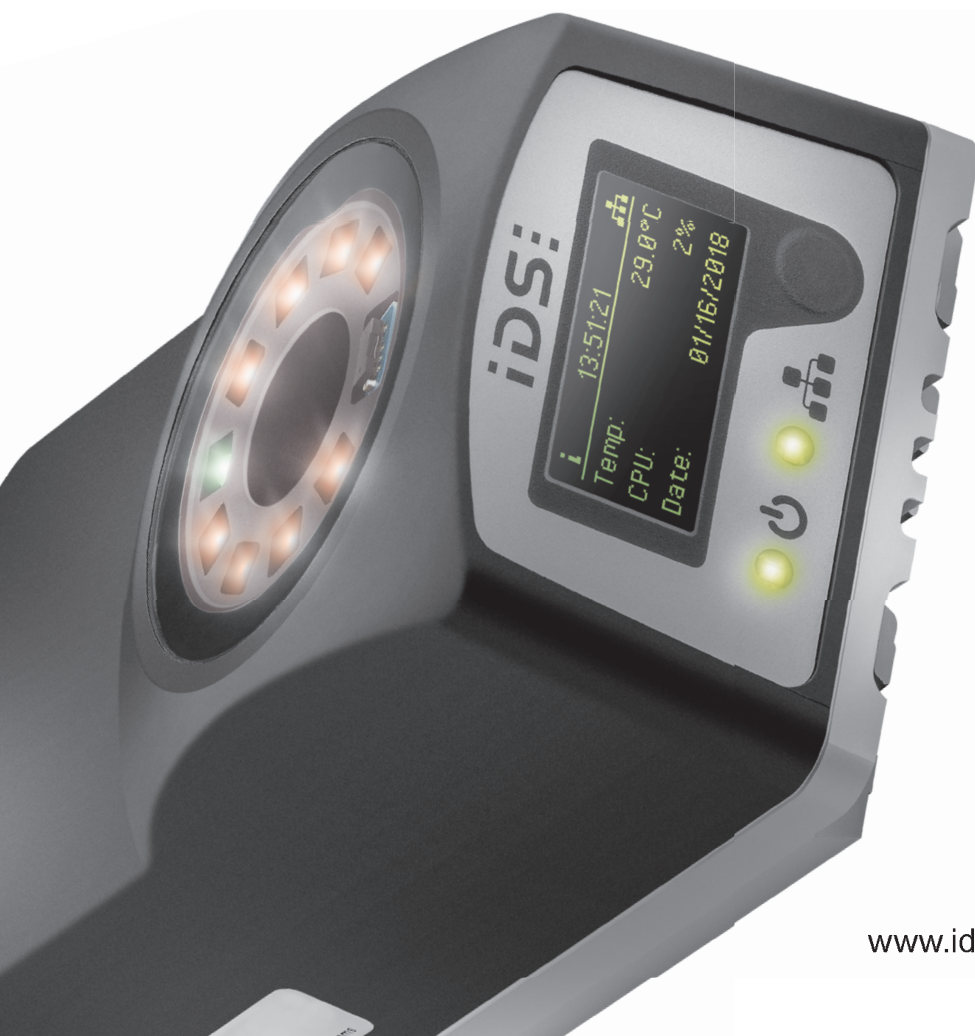

www.ids-nxt.com

IDS:



UKIVA
machine vision
conference
 & EXHIBITION

16 May 2018
 Arena MK, Milton Keynes, UK

www.machinevisionconference.co.uk

Conference Programme & Exhibitor List

3D VISION

- 10.00 Keynote presentation 1**
Prof Tony Pipe, Bristol Robotics Laboratory, UWE
- 10.30 3D Vision
Photonfocus AG
- 11.00 Deeper into the 3rd Dimension
Simon Hickman, Multipix Imaging
- 11.30 3D Vision – complementing 2D not replacing it
Peter Dietrich, IDS Imaging Development Systems
- 12.00 Realtime 3D robot vision as a salmon killer
Thor Vollset, Scorpion Vision
- 14.00 Keynote presentation 2**
Henry Harris-Burland, Starship Tech
- 14.30 3D vision in the industrial & mobile industry
David Lievesley, IFM Electronic
- 15.00 Multi-3D sensor set-ups and acceleration capabilities made easy
Lucien Vleugels, LMI Technologies

What to expect:

In 2017 the 3D Vision theatre attracted the highest audiences and there is another rich program scheduled for 2018.

Simon Hickman will be looking at several 3D Imaging technologies, including a new 3D projection method for camera integration with robots and cobots. *Peter Dietrich* will discuss how 3D data can be combined with 2D information to provide a more effective system in applications such as localisation and verification.

Thor Vollset will describe a recent innovation in fish farms using robots and advanced realtime 3D machine vision to kill salmon moving on a conveyor. *David Lievesley* will be covering various solutions where 3D vision provides robot guidance and the AGV market where the 3D vision is used for obstacle avoidance.

Lucien Vleugels will show how multi-sensor support allows users to configure 3D sensor layouts and align them to a common coordinate system.

CAMERA TECHNOLOGY

- 10.30 Higher bandwidth Interfaces widen the Machine Vision World
Sören Böge, Basler AG
- 11.00 Transitioning From GigE to 10 GigE
Myriam Beraneck, FLIR Systems (formerly Point Grey)
- 11.30 Getting the most from an on-board FPGA
Horst Mattfeldt, Matrix Vision GmbH
- 12.00 How TDI and WDR in area scan cameras increase imaging performance
Nathan Cohen, Imperx
- 14.30 Superior Colour Imaging with Multi-Sensor Cameras
Christian Felsheim, JAI
- 15.00 Lens Control & Industrial Cameras Finally Merge!
Sebastian Bachmann, SVS-Vistek GmbH
- 15.30 TDI Technology (cameras)
Vieworks

What to expect:

Camera technology continues to evolve, whether through the emergence of new data transmission standards, new sensors or ways of getting more out of existing sensors.

Sören Böge offers an introduction to the 5GigE and 10GigE interfaces and possible applications. *Myriam Beraneck* will give a brief overview of consumer and industrial 10GigE hardware trends; the impact of various parameters on overall system performance, and key factors when transitioning from GigE to 10 GigE.

Nathan Cohen will look at ways to achieve imaging performance beyond the specifications of the sensor, including TDI and WDR. *Christian Felsheim* will cover the introduction of multi-CMOS line and area scan cameras for applications utilising colour information to differentiate material composition for sorting applications.

Sebastian Bachmann will explore how, with the latest lens and camera technology, full control of lenses and an industrial camera is now possible.

DEEP LEARNING & EMBEDDED VISION

- 10.30 **Hot Topic “Deep Learning”**
Adriano Biocchi, MVTec Software GmbH
- 11.00 **Machine Learning**
Dr Jon Vickers, Stemmer Imaging Ltd
- 11.30 **Demystifying Machine Learning for Machine Vision**
Jason MacDonald, Matrox Imaging
- 12.00 **High-speed image acquisition with real-time GPU processing**
Frans Vermeulen, Active Silicon Ltd
- 14.30 **New potentials of embedded vision systems in industrial inspection through smart vision architectures**
Tim Miller, New Electronic Technology GmbH
- 15.00 **What is Embedded Vision**
Stuart Chaston, Framos GmbH
- 15.30 **Lighting for Robot Vision**
Andreas Bayer, MBJ Imaging GmbH

What to expect:

With deep learning such a hot topic in the field of machine vision, there is plenty of opportunity to find out more about this topic. Deep learning is a part of the larger ‘machine learning’ body of work. In his presentation, *Adriano Biocchi* will be giving answers to the several key questions, including: which applications can deep learning be used for, and what are the big advantages of deep learning?

Dr. Jon Vickers will be aiming to take the audience from zero knowledge of machine learning to understanding the state of the art, showing the kinds of applications that typically succeed and, crucially, where machine learning is not the correct choice.

Jason MacDonald will begin his session with a brief historical overview of neural network (NN) technology, then discuss its applicability and limits for machine vision and touch on the benefits and challenges of applying it effectively.

Embedded vision is gaining real traction in machine vision, especially where the economies of scale can be realised.

Tim Miller will be aiming to provide guidance to embedded vision system developers, on how the combination of CMOS technology in the camera and sequential and parallel processing opens up potential new machine vision architectures. This will be supported by real case studies.

Stuart Chaston will be providing clarity on the differences between embedded vision and regular vision and why the industry as a whole is migrating to Embedded Vision.

UNDERSTANDING VISION TECHNOLOGY

- 10.30 **CoaXPress state of the art and future perspectives**
Jean Caron, Euresys
- 11.00 **Current Vision Sensors and what lenses to use with them**
Raf Slotwinski, Alrad Imaging
- 11.30 **The technology of vision sensors – capabilities & limitations**
Andrew Moran, Baumer Limited
- 12.00 **Solving manufacturing challenges with Cognex Vision**
Brian Davies, Cognex
- 14.30 **“Vision Systems Don’t Work!”**
Allan Anderson, ClearView Imaging Ltd
- 15.00 **Camera sensitivity – compare and contrast**
Peter Dietrich, IDS Imaging Development Systems Limited
- 15.30 **5.30 IPC platforms, integrated vision and control**
Bradley McEwan, Beckhoff Automation Ltd

What to expect:

Standards and specifications are a hugely important part of industrial vision in terms of determining the most suitable imaging components and systems. *Jean Caron* will give an overview of the CoaXPress standard including the key features and benefits of this technology and an update relative to the latest version of the CoaXPress..

Raf Slotwinski will examine the challenges in choosing the correct optics to meet the ever growing developments in CMOS and InGaAs sensors and suggest solutions.

Brian Davies will cover a wide range of applications using examples from the food and beverages industry and explain how vision can help you overcome manufacturing challenges.

Even though machine vision technology is becoming more mainstream and more mature, many systems still fail, fail frequently and even fail spectacularly with the loss of time and money. *Allan Anderson* will examine the key areas where failures most frequently occur and offer guidance on how these failures and mistakes can be avoided.

Peter Dietrich will discuss camera sensitivity and discuss how standard committees like EMVA and ISO try to help sort things out by defining procedures for measuring several key performance parameters of a camera or camera system, respectively.

Andreas Bayer will describe the specific requirements for robotic lights in machine vision robot applications.

SYSTEMS & APPLICATIONS

- 10.30 **CamView – integrating vision with machine performance for the Internet of Things**
John Dunlop, Bytronic Automation
- 11.00 **How Cobots are revolutionising Vision Systems**
Paul Cunningham, Acrovision
- 11.30 **How machine vision helped this pharmaceutical site to reduce rework by 1 tonne/day**
Phil Dearnaley, Crest Solutions
- 12.00 **Robotics & Vision, a Match made in Perfect Harmony**
Neil Sandhu, SICK (UK) Ltd
- 14.30 **Using 3D in Food Processing**
Paul Wilson, Scorpion Vision Ltd
- 15.00 **Vision Technologies for Round Consumer Packaging**
John Eicholtz, Mettler Toledo UK
- 15.30 **Integrated machine vision - Look beyond embedded**
B & R Industrial Automation Ltd

What to expect:

This theatre will highlight some of the many vision systems available, including the combination of vision systems and robotics which opens up an even wider range of applications. *John Dunlop* will describe an IoT tool for capturing slow-motion video of machine faults to assist users to maintain and improve manufacturing lines, maximising their output. The small battery-powered cameras record the effects and are triggered by the monitoring system to upload video to cloud-based storage.

Paul Cunningham will talk about using cost-effective, inherently collaborative robots (cobots) with vision inspection systems for applications from robot guidance to pick and place, to multi-part inspection. *Phil Dearnaley* will describe the challenges facing a pharmaceutical manufacturing site, as well as providing insight into how the right vision application has dramatically increased site efficiencies while achieving full compliance with FDA regulations.

With robots and cobots now becoming more and more part of daily life and even more so within industry, *Neil Sandhu* will present an overview of robotics and machine vision and showcase their symbiotic nature in development from initial systems to the present day and looking into the future. *Paul Wilson* will be presenting a low profile 3D camera which utilises stereo vision and random pattern projection. This single camera has split optics which have the ability to create a very compact 3D system able to measure depth and length of small objects, with universal application across all industry sectors.

B & R Industrial Automation will be discussing a new fully integrated control solution to provide real-time feedback from imaging-based inspection for self-optimising production processes.

OPTICS & ILLUMINATION

- 10.30 **Hyperspectral and Reciprocal Lighting and Imaging**
Vincent Guenebaut, CVR Lighting
- 11.00 **Are standardization & lighting compatible in machine vision?**
Vincent Le Siou, Effilux
- 11.30 **A look at latest advances in MV LED lighting**
Tony Carpenter, Smart Vision Lights
- 12.00 **High resolution lenses for the new higher resolution sensors**
Graeme Thursfield, Ricoh International B.V. German Branch
- 14.30 **Solving vision problems through lighting control**
Jools Hudson, Gardasoft
- 15.00 **Innovations in Machine Vision: Benefits of Multi-Spectrum Lighting**
Tristan Smith, Keyence UK Ltd
- 15.30 **The Pitfalls of Optics Sourcing; Reducing Costs and Hassle**
Dr Heather Booth, Comar Optics

What to expect:

Optics and illumination lie at the heart of the type and quality of the image presented to a camera. *Vincent Guenebaut* will present a new unique approach which optimises the capabilities of hyperspectral imaging in segregating the intensity of features in an image according to their wavelength. When used in conjunction with a proper lighting system, it can produce astonishing results.

Vincent Le Siou will explain why it is difficult to standardise machine vision lighting due to the diversity of industrial applications (reflective, colour, size, material etc.) and discuss some solutions which will allow the user to have a “all-in-one” lighting system. *Tony Carpenter* will look at 3 main areas that are needed in the supply of MV LED lighting based on the continuing trends of faster production lines, multi-product production lines, and the optical performance necessary to answer manufacturing trends.

Jools Hudson will cover some practical examples which illustrate the cause of poor results in machine vision applications due to variations in illumination intensity and highlights the benefits of precision lighting control. *Tristan Smith* will introduce multi-spectrum lighting. Beginning with the main concepts behind the technique, he will explore the features and advantages of full-spectrum illumination across a range of different industries and applications.

Dr Heather Booth's presentation discusses the nature of the optics industry, the common pitfalls when sourcing optics and solutions to overcome them. She will present real examples of issues and discuss the hidden costs when specifying and buying production optics.

VISION INNOVATIONS

- 10.30 Vision guided warehousing robots**
Kane Luo, Hikvision
- 11.00 Smart Vision developing into the App World, the Cloud and Beyond...**
Neil Sandhu, SICK (UK) Ltd
- 11.30 The future of Thermal Imaging in Machine Vision**
Andreas Lange, Teledyne Dalsa
- 12.00 4k Imaging Combining Cameras and Lenses**
Brigitte Vachon and Patrick Buve, PixeLINK, a Navitar company
- 14.30 Industrial Assemblies – How to choose the right assembly for your application**
Matthew Simons, Alysium-Tech GmbH
- 15.00 The benefits of ‘embedded’ optical filters for machine vision applications**
Yusuke Suzuki, Sony Image Sensing Solutions
- 15.30 Multispectral Imaging: More Than Just a Picture**
Dany Longvel, Lumenera Corporation

What to expect:

The vision industry is characterised by the sheer pace of change and development and some of these will be covered here.

Neil Sandhu will explore where machine vision inspection has come from and how well it has been utilised throughout industry going towards current trends, methods and practices with an insight into the future. Both 2D and 3D technologies will be discussed.

Andreas Lange will aim to illustrate specific technological requirements during the development and manufacturing process of uncooled LWIR detectors, discuss the next big trend like wafer-level packaging, and highlight different techniques that allow the implementation of specific feature sets to meet the different conditions in industrial applications.

Matthew Simons will show how choosing the correct cable assembly can solve application based challenges such as noisy environments and longer distances, before they even appear.

Yusuke Suzuki will consider how new materials often can prove challenging to inspect, with lighting causing a refraction or glare, and how this can be overcome using a ‘pixel level polarisation filter’ applying reflection removal directly on the CMOS image sensor, negating the need for external filters.

Dany Longvel will discuss multispectral imaging, which is a technology that combines visible and near infrared imaging to extract information beyond what the human eye can see. Applications are found in everything from medical imaging to precision agriculture.



LIST OF EXHIBITORS

The Exhibition features world-class cross section of companies that serve the machine vision industry. These include vision component manufacturers, vision component and system distributors and systems integrators. Visitors to the event will have a great opportunity to see some of the latest vision products and talk to experts about any aspect of machine vision.

Acrovision	http://acrovision.co.uk
Active Silicon	www.activesilicon.com
Allied Vision	www.alliedvision.com
Alrad Imaging	www.alrad.co.uk
Alysium	www.alysium.com
B&R	www.br-automation.com
Basler	www.baslerweb.com
Beckhoff Automation	www.beckhoff.com
Bentham	www.bentham.co.uk
Bytronic Automation	www.bytronic.com
Capture Automation	www.captureautomation.co.uk
ClearView Imaging	www.clearviewimaging.co.uk
Cognex	www.cognex.com
Comar	http://uk.comaroptics.com
Crest Solutions	www.crestsolutions.ie
CVR Lighting	http://cvrlighting.com
Effilux	www.afilux.fr/en
Euresys	www.euresys.com
Framos	www.framos.com
Gardasoft	www.gardasoft.com
Hikvision	www.hikvision.com
IDS	www.ids-imaging.com
ifm electronic	www.ifm.com
Imperx	www.imperx.com
Industrial Vision Systems	www.industrialvision.co.uk
JAI	www.jai.com
Keyence	www.keyence.co.uk
Lambda Photometrics	www.lambdaphoto.co.uk
LMI Technologies	http://lmi3d.com
Lumenera Corporation	www.lumenera.com
MBJ Imaging	www.mbj-imaging.com
Matrix Vision	www.matrix-vision.com
Matrox Imaging	www.matrox.com
Mettler Toledo	www.mt.com
Multipix Imaging	http://multipix.com
MVTec Software	www.mvtec.com
NET	http://net-gmbh.com
Photonfocus	www.photonfocus.com
Pixelink	http://pixelink.com
Point Grey	www.ptgrey.com
Ricoh	www.ricoh.com
Scorpion Vision	www.scorpionvision.co.uk
Sick UK	www.sick.com
Smart Vision Lights	http://smartvisionlights.com
Sony	www.image-sensing-solutions.eu
Stemmer Imaging	www.stemmer-imaging.co.uk
SVS-Vistek	www.svs-vistek.com
Tamron	www.tamron.eu/uk
Teledyne DALSA	www.teledynedalsa.com
Vieworks	http://www.vieworks.com

Tough where it counts.

CX series IP 65/67 cameras for applications with temperatures ranging from -40°C to 70°C .

MONDAY	TUESDAY	WEDNESDAY
F & B control	Glass inspection	Rack-wheel monitoring
-37°	68°	21°
		

Just right for applications which go beyond the ordinary due to dust, water spray or extreme temperatures! A hard-anodized housing makes the new IP 65/67 CX series cameras with up to 12 megapixel resolution suitable for the food and pharmaceutical industries.

Find out more:
www.baumer.com/cameras/IP65-67





Why walk when you can fly?

Meet MIL CoPilot, the interactive environment for Matrox Imaging Library (MIL). Machine vision application developers can plan their course by readily and efficiently experimenting and prototyping with MIL—all without writing a single line of program code. With the trajectory set, MIL CoPilot accelerates the journey towards application deployment with a code generator that produces clear, functional program code in C++, C#, CPython®, and Visual Basic®.

Developers using MIL get projects off the ground quicker and easier than ever before with MIL CoPilot and ready access to Matrox Vision Academy online training.



Available as part of
MIL

Get there faster with a CoPilot
www.matrox.com/imaging/co-pilot/ukiva



ACROVISION

www.acrovision.co.uk

Acrovision adds collaborative robots to portfolio

Acrovision has made this complementary addition to their portfolio, as more frequently, vision applications need item-handling to optimise the image acquisition process. Vision and robots are used together in many ways. Either the vision system is guiding the robot, or providing the robot dimensional data of a component for 'Pick and Place' applications. Or the robot is used to either move the vision camera to the component to be inspected or the component to the camera.

Acrovision is putting together a family of robots to cover the full range of 'Arm-Reach' and 'Payloads' for differing requirements. Collaborative robots (cobots) are particularly suited to providing solutions for the small and medium manufacturing sectors. They have inherent safety features that enable them to work with and alongside humans (subject to a risk assessment) without safety equipment or obstructive and expensive guarding. In addition, the cobot has a 'Guide to teach' function that enables quick and easy programming (no programming skills are needed). Cobots can easily be integrated into existing production systems and can be re-deployed to another application as required.



Collaborative robot

ALLIED VISION

www.alliedvision.com

New Manta models with second generation Sony IMX CMOS Sensor

Allied Vision's Manta GigE camera family now has two new colour and monochrome models incorporating second generation Sony IMX CMOS sensors with Pregius global shutter technology. The Manta G-158 incorporates the IMX273 sensor, offering a resolution of 1.58 megapixels and a frame rate of 75.3 fps at full resolution. The Manta G-040 is equipped with IMX287 sensor delivering a resolution of 0.40 Megapixels and a frame rate of 286 fps at full resolution.

These new Manta models are especially suited for industrial applications that require accurate imaging of fast-moving subjects. Particular highlights are on-board image processing features such as three look-up tables and sophisticated colour correction capabilities, a robust metal housing, and many modular options. The new cameras offer the Trigger over Ethernet (ToE) Action Commands feature. This enables users to externally trigger the Manta cameras via its Power over Ethernet connection, enabling a single cable solution to be realised with data, power, and trigger capabilities. Allied Vision's Vimba software development kit allows easy configuration with its new intuitive user interface.



Manta GigE cameras

B&R INDUSTRIAL AUTOMATION

www.br-automation.com

B&R integrates vision into machine automation

B&R has introduced the world's first image processing solution to be seamlessly incorporated in the automation system. The solution comprises cameras, software and lighting accessories. At the heart of the solution is a broad selection of intelligent camera technology. Options at the lower end will replace simple machine vision sensors, while the top of the range will harness the full potential of high-end smart cameras. Ready-made software components are available for creating applications with minimal new programming.

Lighting elements are available integrated in the camera, as an external device, or even as a combination of the two. Extremely precise synchronization for high-speed image capture and object-specific functions such as bright-field or dark-field illumination are easy to implement. Image triggers and lighting control can be synchronized with the rest of the automation system in hard real time and with sub-microsecond precision. With a single development environment for every aspect of automation, control ramosengineers will now be able to implement many machine vision tasks on their own.



Integrated camera

MEMBERS NEWS



SmartApplets

BAUMER

www.baumer.com

Baumer *SmartApplets* help master complex tasks in image processing

With new *SmartApplets*, Baumer is the first camera manufacturer to introduce an innovative concept to quickly and easily increase the application-specific functionalities of cameras with FPGA-based image processing. *SmartApplets* can be conveniently transferred to the LX *VisualApplets* cameras by means of a firmware update so the camera is immediately ready for use.

As a result, even non-expert users benefit from ready-to-operate solutions for common tasks in image processing without the need to build up special know-how in FPGA programming. They are also no longer required to define image processing algorithms on their own, which allows for a more rapid response to market requirements and significantly cuts down on development costs.

By the end of the year, the first six *SmartApplets* to solve common image processing tasks will be available on the Baumer website for free download: Adaptive binarization; High Dynamic Range image calculation; Image Aggregation; Configurable JPEG lossless image compression; Line Scan Emulation and Object Extraction. Where standard *SmartApplets* functionalities do not suffice in specific applications, *VisualApplets* allows users to perform easy and cost-effective adjustments.



ClearView Imaging receive award

CLEARVIEW IMAGING

www.clearviewimaging.co.uk

ClearView Imaging wins award from FLIR

ClearView Imaging was recently awarded FLIR's Distributor of the Year for 2017. This award was in recognition of outstanding growth, the added value that ClearView offers and customer service provided for FLIR Machine Vision products within the UK and Ireland.

Mike Gibbons, VP for FLIR Machine Vision products commented "We are very proud to work with this team of smart and dedicated vision professionals and thank ClearView for delivering world-class sales, service, and support to our customers in the UK and Ireland."

ClearView Imaging are a leading supplier of Machine Vision components and systems and with a team of dedicated Machine Vision Engineers, can offer service and value by way of consultative advice, feasibility studies, development services, etc.



IMPACT 11.11 Advanced OCR

DATALOGIC S.R.L UK

www.datalogic.com

Datalogic IMPACT Software 11.11 announced

Datalogic is pleased to announce the 11.11 IMPACT software release, designed to bring new functionalities to the MX-E and MX-U vision processors. It delivers the new Advanced OCR tool, an intuitive and an easy to use vision tool for challenging Optical Character Recognition applications.

The powerful advanced OCR tool is able to read challenging alphanumeric strings printed over labels or directly marked (DPM) into industrial products. This new tool ensures robust and reliable reading of hard to read characters under difficult conditions, such as non-uniform background, variable light conditions, and curved surfaces.

IMPACT Software 11.11 with Advanced OCR is ideally suited for reading ink-jet printed dot matrix codes and embossed character (raised or lowered) on product surfaces. Advanced OCR is extremely intuitive featuring quick font and characters training and easy database management and string verification modes. OCR technology finds applications in the Automotive, Electronics, Pharmaceuticals and Food & Beverage industries, including the traceability of Automotive mechanical parts and components, as well as the quality and safety in the Food & Beverage packaging processes.



SUPERIOR

MACHINE VISION IMAGING PRODUCTS

Highest Quality **CMOS** and **CCD** Imaging



MEDICAL & SCIENTIFIC
 AUTOMATION & INSPECTION
 MILITARY & AEROSPACE
 HD-SDI BROADCASTING
 TRANSPORTATION & TRAFFIC
 AERIAL IMAGING

CHEETAH • TIGER • BOBCAT

For more information on the Imperx CMOS Cameras and other Imperx products, please contact us at +44 (0)1730 233332 or sales@multipix.com

IMPERX, INC

6421 Congress Ave., Suite 204, Boca Raton, FL 33487, USA
info@imperx.com • Tel: 1-561-989-0006

www.imperx.com | www.multipix.com



Make an Informed Choice

Research. Specify. Purchase.
At the Scorpion Vision Webshop.



WE SELL:

- MACHINE VISION CAMERAS
- C AND CS MOUNT LENSES
- M12 LENSES
- USB3 CABLES
- OPTICAL ACCESSORIES
- INTERFACES
- VALUE FOR MONEY LED ILLUMINATION



SHOP.SCORPIONVISION.CO.UK

FRAMOSwww.frames.co.uk**First SVLS-EC RX IP Core and EVB for Xilinx FPGAs**

Framos has developed the first SVLS-EC RX IP Core for easy sensor interfacing with FPGAs from Xilinx. The proprietary module, available with an EVB, connects Sony's latest high-speed SVLS-EC (Scalable Low Voltage Signalling with Embedded Clock) interface with Xilinx FPGAs and enables vision engineers to seamlessly upgrade to Sony's interface technology of the future and to create high-performance vision solutions.

Introduced with the 3rd generation Pregius imagers, Sony's new high-speed interface standard SVLS-EC is one of the future image sensor interface benchmarks with up to 8 lanes providing 2.3Gbps each, for three to four times higher bandwidths, higher resolutions or a simplified system design compared to SubLVDS. The RX IP Core reduces overhead and complexity implementing a Sony imager with SVLS-EC. As an on-chip function block connecting the customer's FPGA logic with the image sensor's data stream, the IP Core receives the interface data, manages the byte-to-pixel conversion for various lane configurations and thus prepares a highly-efficient processing workflow run by the FPGA. The SVLS-EC RX IP Core will be released mid-May, 2018.

*Xilinx***IDS IMAGING**www.ids-imaging.com**3D Vision: Now with 5 MP cameras**

The flexible Ensenso X 3D camera systems from IDS are now available with Sony's IMX264 CMOS sensor to provide a larger field of view, more image details, and reduced noise: This 5 MP system captures details and depth information even more precisely. Compared to the previous systems with 1.3 MP sensors, the larger field of view of the 5 MP cameras allows the distance between camera system and object to be reduced significantly. In order to completely capture a packed Euro pallet with a volume of 120 x 80 x 100cm, only 1.25m is required instead of 1.5m. The Z-accuracy improves from 0.43mm to 0.2mm. Customers can choose between compact GigE uEye CP cameras and robust GigE uEye FA cameras with IP65/67 protection class. The application areas of Ensenso X range from robotic parts handling in factory automation (bin picking) to tray and pallet commissioning in warehouse and logistics automation.

*EnsensoX 3D cameras***INDUSTRIAL VISION SYSTEM**www.industrialvision.co.uk**Robot cell inspection**

A video from Industrial Vision Systems (www.youtube.com/watch?v=0u3EbfjyQ0o) shows robot cells produced by IVS operating within a completely automated production line with product transported via autonomous 'Automated Guided Vehicles' (AGV). The machine vision system then completes the inspection without operator input, making decisions dependent on the results it has seen. High definition camera technology, combined with custom LED lighting and laser projectors, allows for flexible automated inspection, increasing productivity, reducing scrap and leveraging increased quality. The use of an AGV to transport sub-assemblies and introduce them into the inspection cells allows for highly flexible movement around the factory. The robot can position the camera head at almost any angle in almost any position, allowing complete three-dimensional checks of parts. The camera system is further combined with both laser projection, and standard LED lighting technology enabling multiple analysis of both standard images and laser edge detection, utilising 2D and 3D vision systems. Using the robot allows a single vision machine to inspect endless parts and variants. This approach allows the client to add new components and modifications to the system capabilities at their leisure.

*IVS Robot inspection*

MEMBERS NEWS



IPS200i

LEUZE ELECTRONIC

www.leuze.co.uk

Smallest camera-based sensor for compartment fine positioning

With the IPS 200i, Leuze electronic is bringing to market the smallest camera-based positioning sensor for the compartment fine positioning of pallets in high-bay warehouses or for small-part container storages. This device offers a smart alternative to conventional vertical and horizontal shelf positioning with multiple diffuse reflection sensors. Tedious mounting, aligning, and readjusting during operation is no longer required, saving the customer valuable time.

The IPS 200i facilitates easy and quick commissioning and operation. The web-based, multi-language configuration tool with a user-guided wizard reduces the times it takes for commissioning to a minimum. The IPS 200i can also be configured by XML commands or intuitively started up and operated via just two buttons, without being connected to a PC. Innovative feedback LEDs offer instant feedback, which makes aligning the sensors as easy as parking a car. Due to powerful, ambient-light-independent IR LED lighting, a single device can be flexibly used for the entire working range of up to 600 mm. A model with integrated heating for use in refrigerated warehouses down to -30 °C is also available.

MATROX IMAGING

www.matrox.com

Project Change Validator launched to safeguard vision systems

Matrox® Imaging has announced Project Change Validator, a modification proofing utility that ensures machine vision systems uphold inspection requirements following any new project updates. Available in the Matrox Design Assistant 5.1 flowchart-based machine vision software, Project Change Validator provides production managers the comfort that all project modifications maintain inspection integrity.

Project Change Validator brings enhanced inspection standards to manufacturing environments by minimizing subjective, end-user interventions that could potentially be detrimental to a project. An easy-to-integrate, easy-to-use tool allows quality control managers to run the utility to record a defined set of reference images, along with the associated inspection settings and results, and use this as a baseline project. A server then performs the validation, permitting production personnel to compare current projects against the reference data and readily detect any invalid changes or anomalies. Users can run the utility remotely via the Matrox Design Assistant web portal, which provides access to the validation data as well as the validation results.

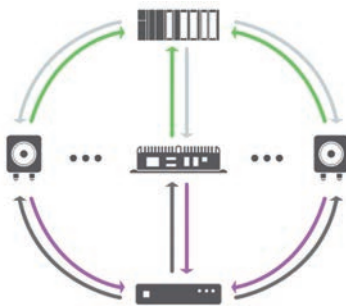

- | | |
|--|--|
| <p>1 Programmable logic controller (PLC)
sends project validation request to vision system(s)</p> <p>2 Vision system(s)
sends current project to validation server</p> | <p>3 Validation server
verifies project and returns status to vision system(s)</p> <p>4 Vision system(s)
forwards validation status to PLC</p> |
|--|--|

Project Change Validator



Halcon 17.12

MULTIPIX

www.multipix.com

Deep learning the new HALCON 17.12 imaging software

Multipix Imaging launch MVTec's latest HALCON Imaging Software which includes an extensive set of cutting-edge deep learning function that can be readily applied to industrial inspection tasks. Customers can train their own CNNs (Convolutional Neural Networks) on the basis of deep learning algorithms, using a sufficient amount of labelled training images, allowing for differentiation between sample images that show defects/contamination and good image samples. Image data can now be classified easily and precisely, thus reducing programming effort and saving both time and money.

HALCON 17.12 also enables users to inspect specular and partially specular surfaces to detect defects by applying the principle of deflectometry. Another highlight is the improved automatic text reader, which has become even better at detecting and reading letters and numbers that are touching. The software also offers a new method to fuse the data from different 3D point clouds into one unified model. This new method is able to combine data from various 3D sensors, even from different types like a stereo camera, a time of flight camera, and fringe projection.

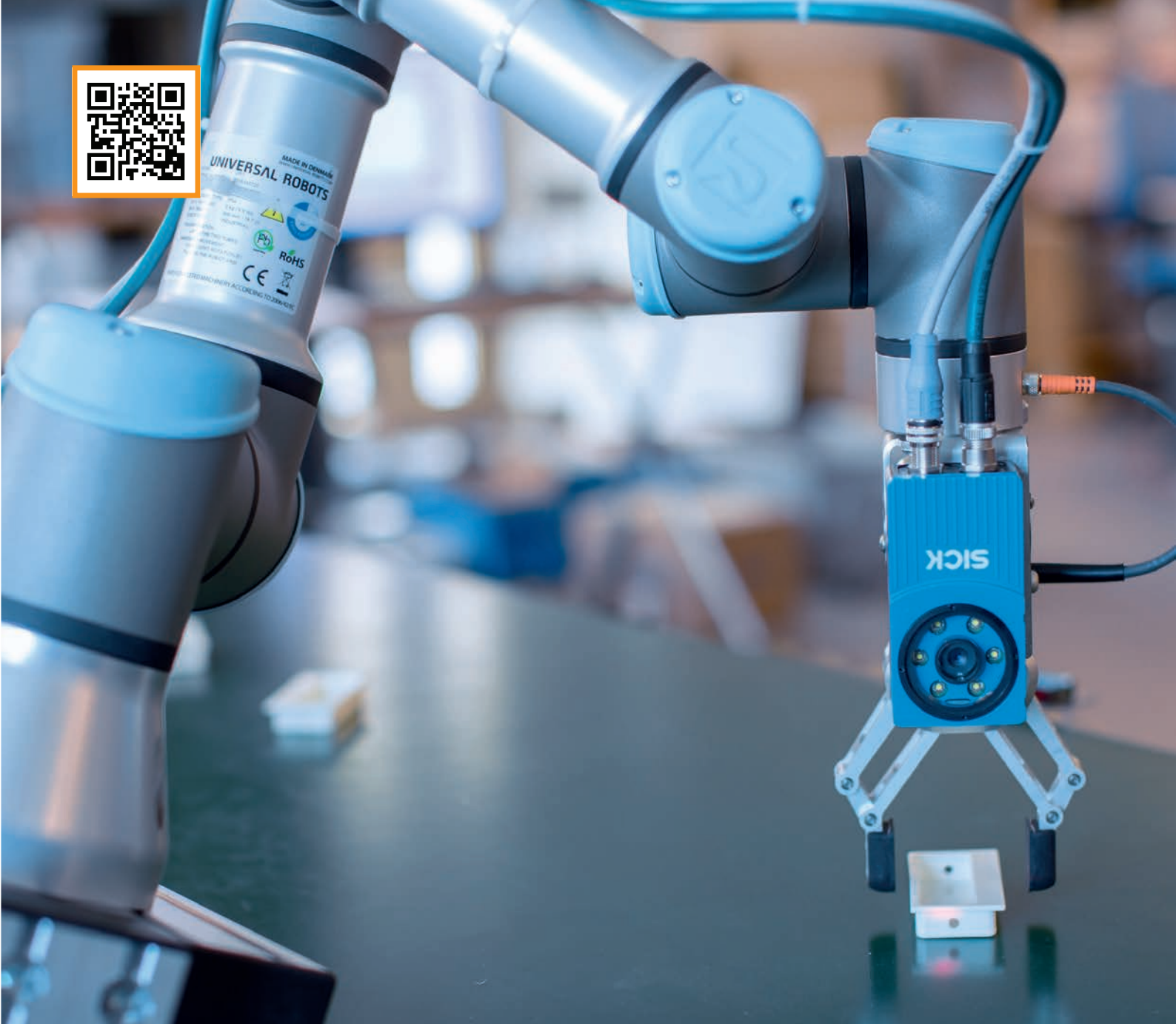

GIVING VISION TO ROBOTS:
THE ABILITY TO SEE ENABLES MORE APPLICATIONS

THIS IS **SICK**

Sensor Intelligence.

Cobots are flexible, lightweight and user-friendly robots. They are easy to deploy in varying applications, in areas such as packaging & palletising, machine tending, pick & place, assembly and quality inspection. Attaching vision technology to the cobot, like the SICK Inspector PIM60, enables it to perform a new variety of tasks. The Inspector provides localisation, can store up to 32 different configurations and perform calculations on-board, so no need for an external computer. We think that's intelligent. www.sick.co.uk/vision-resource



UKIVA
machine vision
conference
& EXHIBITION
16 May 2018
Arena MK, Milton Keynes, UK

PPMA

SHOW 2018

25-27 SEPT 2018
NEC, BIRMINGHAM

**FREE
TO ATTEND
REGISTER
NOW!**

THE UK'S LEADING PRODUCTION LINE EVENT

See the latest **processing
and packaging machinery**
in action, network with industry
peers and gain valuable insight
at our must attend seminars.

30th
ANNIVERSARY



ppmashow.co.uk



PROCESSING & PACKAGING MACHINERY
MATERIALS | ROBOTS | INDUSTRIAL VISION

ORGANISED BY
PPMA GROUP OF
ASSOCIATIONS

SCORPION VISIONwww.scorpionvision.co.uk**Hikvision VPU Smart Camera from Scorpion Vision**

The Hikvision VPU Industrial Smart Camera is a high quality device that can be used in a variety of applications, including logistics barcode reading and factory automation. The Movidius VPU Platform has parallel high speed image processing with embedded code-reading algorithms, allowing it to read 1D codes efficiently even if they are dirty, defective or have low contrast.

This smart camera also features multiple trigger modes (single-frame trigger, multiple-frame trigger, Burst), and a Gigabit Ethernet interface providing 1Gbps bandwidth with a variety of I/O Interfaces. The unit uses multiple indicator lights to guide the set-up process and to display the performance. Packaged in an IP65 protection level casing with its own light source, the smart camera meets all the requirements of harsh industrial environments.

*VPU Smart Code Reader***SICK (UK) LTD**www.sick.co.uk**Cobot tool for Universal Robots**

SICK has collaborated with Universal Robots to develop an entry-level vision-guided robot solution for pick and place, inspection and measurement that integrates SICK Inspector PIM60 2D vision sensors with U3, U5 and U10 robots. The Inspector PIM60 URcap is simple to set up and use, yet is a powerful toolkit for creating a vision-guided robot task with minimum time and effort. Configuration tasks such as changing jobs and pick-points, calibration and alignment are done directly from the robot control pendant for speed and ease. Configuration is achieved in minutes through the UR controller or the Inspector PIM60 without need for an additional PC.

More advanced tasks such as inspection and dimension measurement of objects prior to picking can be configured via the simple SICK SOPAS tool, providing access to the full range of Inspector PIM60's capabilities and enabling output of additional detailed inspection and measurement results.

*Inspector PIM60 URcap***STEMMER IMAGING**www.stemmer-imaging.co.uk**ADLINK NEON smart camera with choice of software**

Stemmer Imaging can offer ADLINK's x86 NEON-1021 smart camera with a choice of Teledyne DALSA Sherlock, Stemmer Imaging Common Vision Blox or MVTec Merlic embedded software. This means that users can choose the image processing platform that best suits their application needs and be guaranteed a rich range of image processing functionality.

The NEON-1021 features Intel® Atom™ quad core 1.91 GHz processors for increased computing power. FPGA coprocessors and GPU deliver advanced image processing, both beyond the capabilities of conventional smart cameras and allow the camera to process multiple complex inspection tasks simultaneously.

The NEON-1021 feature 2MP global shutter image sensors. A built-in PWM lighting control module eliminates the need for additional lighting controller equipment, reducing total cost of ownership. Optimized I/O includes one additional slave GigE Vision camera connection, 4x isolated input, 4x isolated output, and VGA output for maximized integration with external devices. Rugged construction with IP67-rated housing and M12 connectors enables the camera to withstand the harshest industrial environments.

*Adlink Neon-1021*

MEMBERS DIRECTORY

VISION TECHNOLOGY PROVIDERS

ALLIED VISION T 0207 1934408	www.alliedvision.com
ALRAD IMAGING T 01635 30345	www.alrad.co.uk
BAUMER T: 01793 783839	www.baumer.com
CLEARVIEW IMAGING T: 01844 217270	www.clearviewimaging.co.uk
COGNEX UK T: 0121 296 5163	www.cognex.com
CREST SOLUTIONS T: +353 (0) 21 452 47 67	www.crestsolutions.ie
DATALOGIC S.R.L. UK T: 01582 790020	www.datalogic.com
FRAMOS ELECTRONICS T: 01276 404 140	www.framos.co.uk
HEUFT SYSTEMTECHNIK T: 0182 725 58 00	www.heuft.com
HIKVISION UK T: 01628 902140	
IDS T: 011897 01704	www.ids-imaging.com
IFM ELECTRONIC T: 020 8213 0000	www.ifm.com/uk
IMPERX INCORPORATED T: +1 561 989 0006	www.imperx.com
LAMBDA PHOTOMETRICS T: 01582 764334	www.lambdaphoto.co.uk
LAETUS T: +49 6257 5009-0	www.laetus.com
LEUZE ELECTRONIC T: 01480 408500	www.leuze.co.uk
MATROX IMAGING T: +1 514 822 6020	www.matrox.com/imaging
MULTIPIX IMAGING T: 01730 233332	www.multipix.com
OMRON T: 01908 258 258	www.industrial.omron.co.uk/vision
PYGSA SISTEMAS Y APLICACIONES T: +34 961 85 6867	www.pygsa.es
SCORPION VISION T: 01590 679 333	www.scorpionvision.co.uk
SICK (UK) T: 01727 831121	www.sick.co.uk
SONY T: 01932 816000	www.image-sensing-solutions.eu
STEMMER IMAGING T: 01252 780000	www.stemmer-imaging.co.uk
TAMRON T: +49 221 97 03 25 66	www.tamron.eu/uk
WENGLOR SENSORIC T: 01536 313580	www.wenglor.com

VISION SYSTEMS INTEGRATORS & CONSULTANTS

ACROVISION T: 0845 337 0250	www.acrovision.co.uk
B&R INDUSTRIAL AUTOMATION T: 01733 371320	www.br-automation.com
BYTRONIC AUTOMATION T: 01564 793174	www.bytronic.com
FISHER SMITH T: 01933 625162	www.fishersmith.co.uk
INDUSTRIAL VISION SYSTEMS T: 01865 823322	www.industrialvision.co.uk
OLMEC-UK T: 01652 631960	www.olmec-uk.com
PANTHER VISION T: 01252 713285	www.panther-vision.co.uk
RNA AUTOMATION T: 0121 749 2566	www.rnaautomation.com
SMV T: 0845 5190484	www.scandinavianmv.co.uk

SOLUTIONS THAT UTILISE MACHINE VISION

ALTEC ENGINEERING T: 0191 377 0555	www.alteceng.co.uk
DIMACO (UK) T: 01234 851515	www.dimaco.co.uk
FT SYSTEM T: 07931 336 177	www.ftsystem.com
METTLER-TOLEDO T: 0116 235 7070	www.mt.com
MULTIVAC UK T: 01793 425800	www.multivac.co.uk
STEIN SOLUTIONS T: 07787 568307	www.stein-solutions.co.uk

EVENTS

UKIVA Machine Vision Conference and Exhibition 2018 16 May, 2018, Arena MK, Milton Keynes, UK

Keynote addresses, educational technical seminars and machine vision exhibition.
www.machinevisionconference.co.uk

Multipix WiseUp – Embedded Vision Solutions 11 April, 2018, Advanced Manufacturing, Coventry, UK 12 April, 2018, AMRC, Sheffield, UK

A look at the ever growing area of embedded vision solutions and associated products.
<http://multipix.com/events>

PPMA Show

25 - 27 September, 2018, NEC, Birmingham, UK

Many UKIVA members will be exhibiting
www.ppmashow.co.uk

Photonex

10 - 11 October, 2018, Ricoh Arena, Coventry, UK

www.photonex.org

VISION

6 - 8 November, 2018, Messe Stuttgart, Germany

Many UKIVA members will be exhibiting
www.messe-stuttgart.de/vision/en

TRAINING

Training courses offered by UKIVA members:

STEMMER IMAGING

(in association with the European Imaging Academy)

'Machine Vision Solutions From Teledyne DALSA' – March 21 - 22 and May 9 - 10

'Machine Vision Solutions' – March 29 and September 13

'Optics & Illumination' – April 4

'Hyperspectral Imaging' – April 19

'LMI 3D Sensor' – May 24

'Common Vision Blox' – June 7 and August 2

'Line Scan Technologies' – June 21

'FPGA Programming with Silicon Software Visual Applets' July 7

All courses at Tongham, UK

www.stemmer-imaging.co.uk/en/events/training-events/

TECHNICAL TIPS

Some useful technical tips from UKIVA members

Trigger over Ethernet versus other trigger modes (Allied Vision)

www.alliedvision.com/en/blog/detail/news/trigger-over-ethernet-versus-other-trigger-modes.html

Greater resolution in monochrome mode:

How to get greater resolution from your colour sensor
(IDS Imaging Development Systems)

https://en.ids-imaging.com/tl_files/downloads/techtip/TechTip_18MP-color-sensor-as-mono_EN.pdf

What is Embedded Vision?

(Multipix Imaging)

<http://multipix.com/what-is-embedded-vision>

Making machine vision robust

(Stemmer Imaging)

www.stemmer-imaging.co.uk/en/technical-tips/making-machine-vision-robust/



Machine Vision Solutions tailored to your needs

Scandinavian Machine Vision offer machine vision solutions for quality control, automation and process control. Our solutions are based on a wide range of technologies for 2D, 3D, IR and multi spectral imaging utilizing state of the art image analysis tools.

It is our mission to supply our customers with the best possible solution within set specifications, time and cost. We do this by combining proven products from leading suppliers with innovative thinking, deep knowledge and extensive experience.

For more information and a free consultation on machine vision solutions for:

- Quality assessment
- Process control
- Automation
- Robotics
- For any manufacturing and process industry

please contact John Larsson 0845 519 0484

Oxford Centre for Innovation, New Road, Oxford OX1 1BY United Kingdom
E: john.larsson@scandinavianmv.co.uk T: +44 (0) 845 519 0484 M: +44 (0) 755 768 8760
www.scandinavianmv.co.uk



Smart sensing in 3D



Built-in apps make 3D sensor easy to use

ifm's amazing smart time-of-flight 3D sensor has built-in apps for;

- Completeness in packaging or palletising
- Checking volumes in materials handling
- Levels of bulk material

Making it so easy to set up, anyone can do it.

You'll be amazed!



www.ifm.com/uk/o3d

ifm Telephone (020) 8213 1111



SHOP ONLINE

Machine Vision Specialists, Understanding Your Needs

Multipix Imaging, your independent vision components supplier,
focused on helping you solve your application requirements.

Come to the home of knowledge and experience you can rely on.



BE SMART. CHOOSE MULTIPIX.

www.multipix.com

01 730 233332

MultiPix
imaging

